

CMT527 Reference User Manual

V3.202505

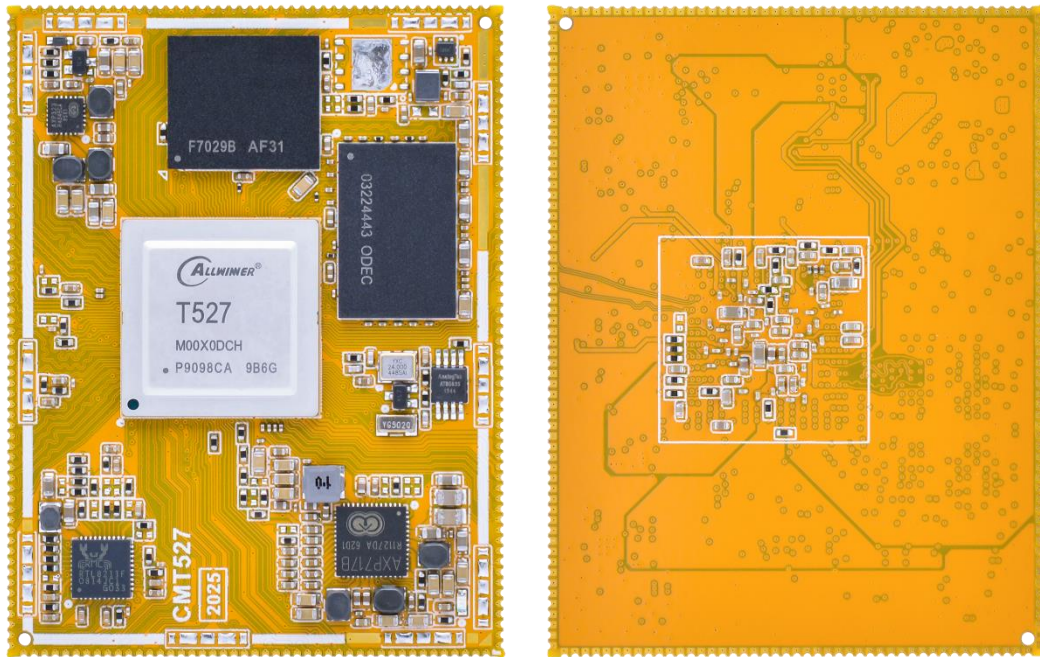

Boardcon Embedded Design

www.armdesigner.com

1. Introduction

1.1. About this Manual

This manual is intended to provide the user with an overview of the board and benefits, complete features specifications, and set up procedures. It contains important safety information as well.

1.2. Feedback and Update to this Manual

To help our customers make the most of our products, we are continually making additional and updated resources available on the Boardcon website (www.boardcon.com , www.armdesigner.com).

These include manuals, application notes, programming examples, and updated software and hardware. Check in periodically to see what's new!

When we are prioritizing work on these updated resources, feedback from customers is the number one influence, If you have questions, comments, or concerns about your product or project, please no hesitate to contact us at support@armdesigner.com.

1.3. Limited Warranty

Boardcon warrants this product to be free of defects in material and workmanship for a period of one year from date of buy. During this warranty period Boardcon will repair or replace the defective unit in accordance with the following process:

A copy of the original invoice must be included when returning the defective unit to Boardcon. This limited warranty does not cover damages resulting from lightning or other power surges, misuse, abuse, abnormal conditions of operation, or attempts to alter or modify the function of the product.

This warranty is limited to the repair or replacement of the defective unit. In no event shall Boardcon be liable or responsible for any loss or damages, including but not limited to any lost profits, incidental or consequential damages, loss of business, or anticipatory profits arising from the use or inability to use this product.

Repairs make after the expiration of the warranty period are subject to a repair charge and the cost of return shipping. Please contact Boardcon to arrange for any repair service and to obtain repair charge information.



Content

1 CMT527 Introduction.....	3
1.1 Summary	3
1.2 Features.....	3
1.3 Block Diagram.....	6
1.4 CMT527 specifications.....	7
1.5 CMT527 PCB Dimension.....	8
1.6 CMT527 Pin Definition.....	8
1.7 Development Kit (IdeaT527)	15
2 Hardware Design Guide.....	16
2.1 Peripheral Circuit Reference.....	16
2.2 Display combination.....	18
3 Product Electrical Characteristics	18
3.1 Dissipation and Temperature	18
3.2 Certifications	19

1 CMT527 Introduction

1.1 Summary

The CMT527 system-on-module is equipped with Allwinner's T527 Octa-core Cortex-A55, G57 MC1 GPU, HiFi4 DSP and 2TOPs NPU(option). It is designed specifically for the smart devices such as industrial controller, AI devices, and automotive devices. The high performance and low power solution can help customers to introduce new technologies more quickly and enhance the overall solution efficiency.

In especial, T527 is support two channels dual LVDS LCD.

1.2 Features

- **Microprocessor**

- Octa-core Cortex-A55 up to 1.8G
- 32KB I-cache, 32KB D-cache, 128KB or 64KB L2 cache per Core
- RISC-V CPU up to 200M
- 16KB I-cache, 16KB D-cache for RISC-V
- Mail-G57 MC1 GPU
- HiFi4 Audio DSP
- Option 2 TOPs NPU with 512KB buffer

- **Memory Organization**

- LPDDR4/x RAM up to 4GB
- EMMC up to 128GB

- **Boot ROM**

- Supports system code download through USB OTG

- **Security ID**

- 4Kbit efuse for security chip ID

- **Video Decoder/Encoder**

- Supports video decoding up to 4K@60fps
- Supports H.264 encode
- H.264 HP encoding up to 4K@25fps
- Picture size up to 4096x4096

- **Display Subsystem**

- **Video Output**

Supports 4+4 lane MIPI DSI up to 4K@45fps

Supports Two channel 4 lane MIPI DSI

Supports HDMI 2.0 transmitter with HDCP 1.4, up to 4K@60fps

Supports Serial RGB interface up to 800x640@60fps

Supports LVDS interface Dual link up to 1920x1080@60fps and Single link up to 1366x768@60fps

Supports Two channel Dual LVDS

Supports RGB interface up to 1920x1080@60fps

Supports Two channel RGB LCD(LCD0 18bit + LCD1 24bit)



Supports BT656 interface for PAL/NTSC

- **Video input**

Supports MIPI CSI input up to 8M@30fps or 4x1080P@25fps

Supports MIPI 4+4 Lane 2-CH input or 4+2+2 Lane 3-CH input

Supports 8bit parallel interfaces

Supports BT656/BT1120 interface

- **Analog audio**

- One stereo headphone output

- One stereo Line output

- Two MIC input

- **I2S/PCM/ AC97**

- Four I2S/PCM interface

- Support up to 8-CH DMIC

- One SPDIF input and output

- **USB/PCIe**

- Three USB 2.0 interfaces

- Option Two USB 2.0 and One USB3.1 interface

- One PCIe 2.1 interface(USB3 Combo PHY)

- **Ethernet**

- Support two Ethernet interface

- One 1GB PHY on CPU Board

- One GMAC/EMAC interface(Option)

- **I2C**

- Up to Eight I2Cs

- Support standard mode and fast mode(up to 400kbit/s)

- **SPI**

- Four SPI controllers, each SPI controller with two CS signals

- Full-duplex synchronous serial interface

- 3 or 4-wire mode

- **UART**

- Up to 9 UART controllers

- UART0 default for debug

- Compatible with industry-standard 16450/16550 UARTs

- Support RS485 mode on 4 wires UARTs

- **CIR**

- One CIR controllers

- Flexible receiver for consumer IR remote control

- **ADC**

- Two channel ADC input

- 12-bit resolution

- Voltage input range between 0V to 1.8V

- **KEYADC**

- One ADC channel for key application

- 6-bit resolution



- Voltage input range between 0V to 1.8V
- Support single, normal and continuous mode
- **PWM**
 - Up 30 PWM channels and 4 PWM controllers
 - Max 16 independent PWMs
 - up to 24/100MHz output frequency
 - Minimum resolution is 1/65536
- **Interrupt Controller**
 - Support **28** interrupts
- **Power unit**
 - AXP717B+AXP323
 - OVP/UVP/OTP/OCP protections
 - DCDC4 3.3V@600mA output(Sleep OFF)
 - Ext-RTC IC on board (**option**)
 - Very low RTC consume current, less 5uA at 3V button Cell (**option**)
- **Temperature**
 - Industrial grade, Operating temperature: -40 ~ 85°C

1.3 Block Diagram

1.3.1 T527 Block Diagram

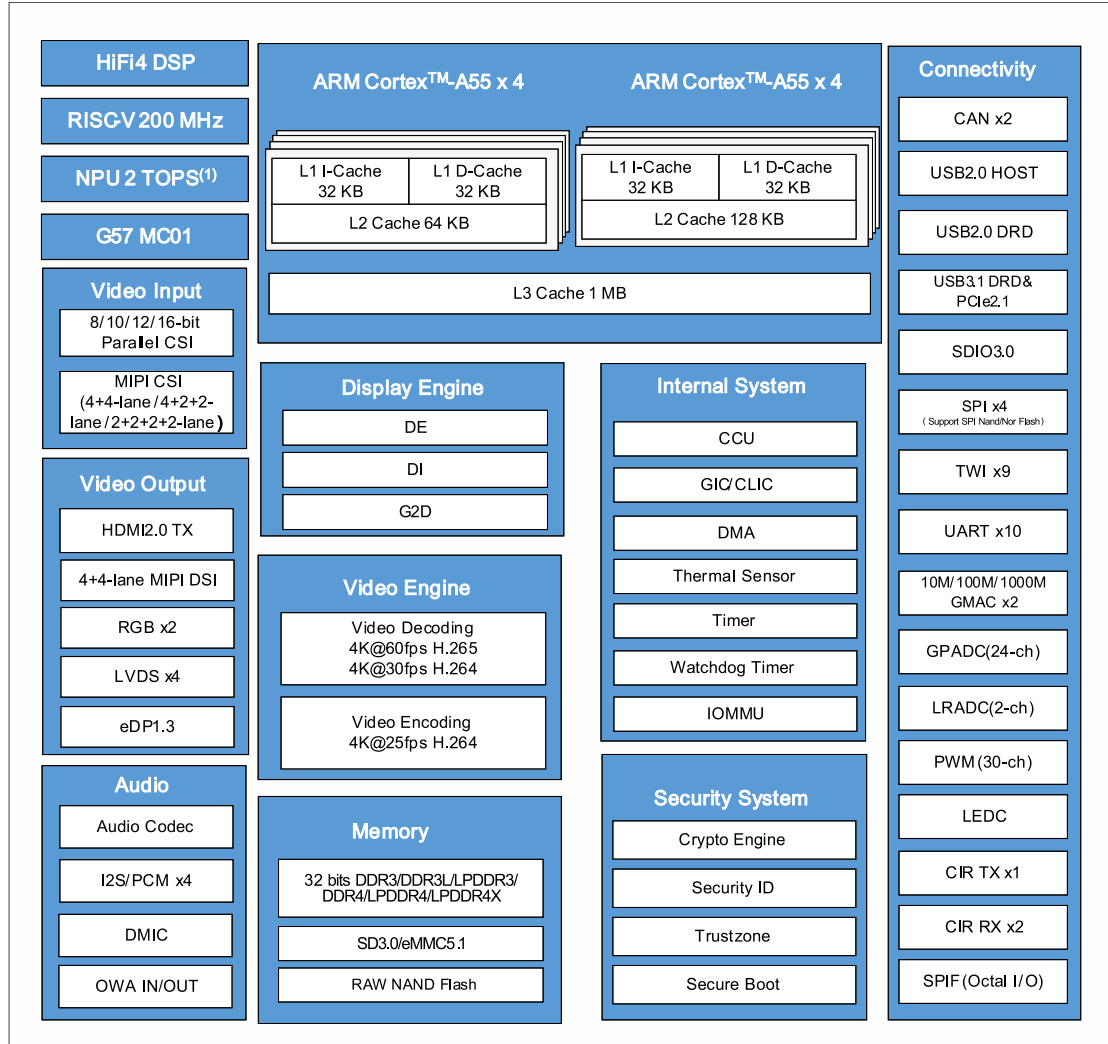

(1) Some modules shown in this block diagram are not offered on all devices.

1.3.2 Development board (IdeaT527) Block Diagram

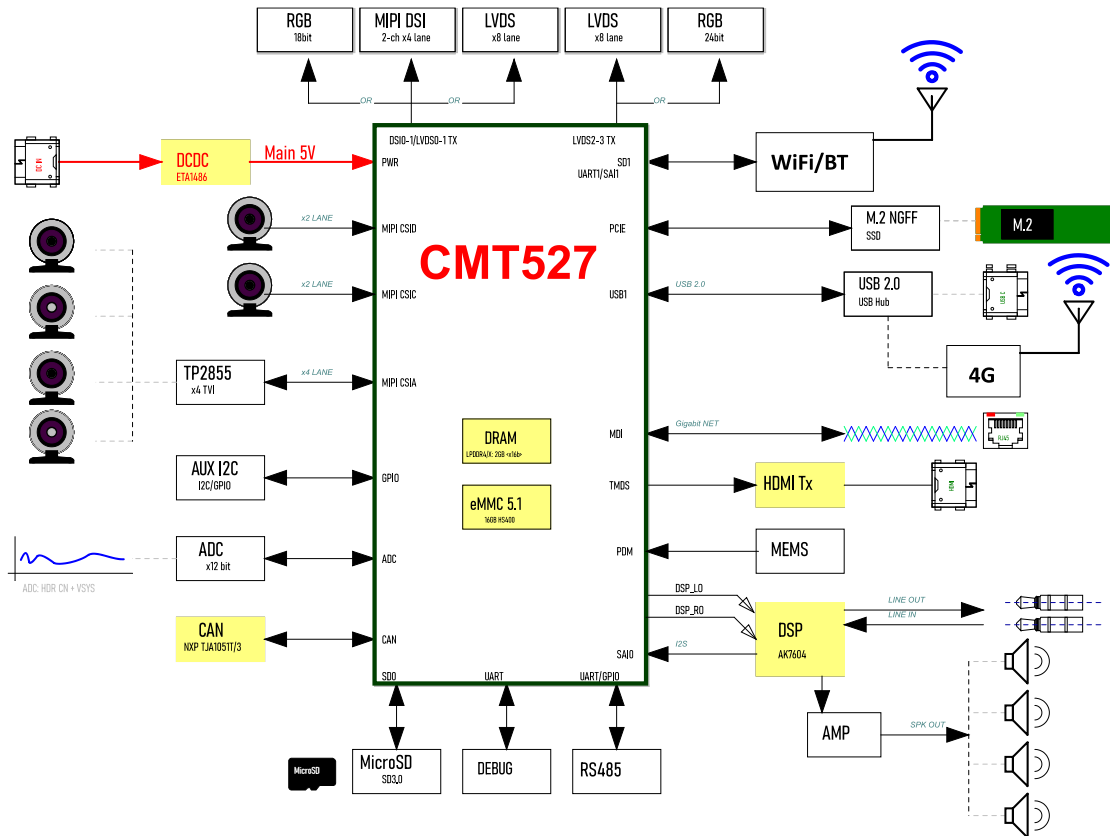

1.4 CMT527 specifications

Feature	Specifications
CPU	Octa-core Cortex-A55
DDR	2GB LPDDR4x (up to 4GB)
eMMC FLASH	8GB (up to 64GB)
Power	DC 5V
LVDS LCD	2CH up to dual LVDS
DSI LCD	2CH 4-Lane LVDS(option)
RGB LCD	2CH LCD0(18bit)+LCD1(24bit) (option)
I2S	4-CH
MIPI_CSI	3-CH(1-CH 4 Lane + 2-CH 2 Lane)
DVP Camera	1-CH(option)
HDMI out	1-CH
USB	2-CH Host (1 USB2 + 1 USB3), 1-CH(OTG 2.0)
PCIE	1-CH(option)
Ethernet	1 RGMII/RMII interface And 1000M PHY on board



Feature	Specifications
SDMMC	2-CH
SPDIF RX/TX	1-CH
I2C	8-CH
SPI	4-CH
UART	8-CH, 1-CH(DEBUG)
PWM	30-CH
ADC IN	3-CH
Board Dimension	56 x 42.5mm

1.5 CMT527 PCB Dimension

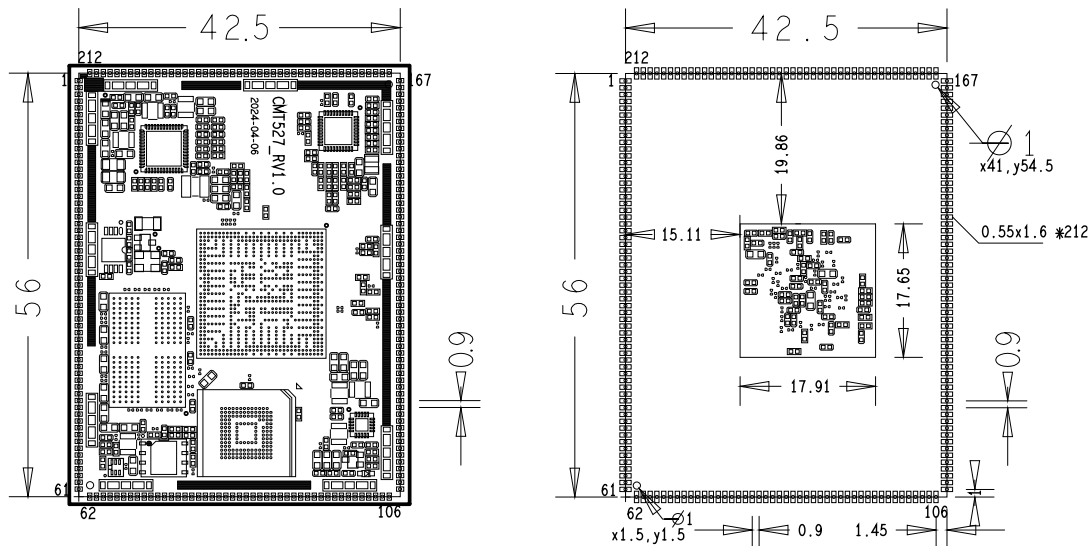

--Top View--

1.6 CMT527 Pin Definition

Pin	Signal	Description	Alternate functions	IO Voltage
1	DCIN	Main Power input		3.9V-5.5V
2	DCIN	Main Power input		3.9V-5.5V
3	DCIN	Main Power input		3.9V-5.5V
4	GND	Ground		0V
5	PWRON	Power key input		1.8V
6	VCCIO-3V3	GPIO Power output	Max 600mA	3.3V
7	MBIAS	MIC Power output		1.8V
8	MICIN1N	Microphone negative input1		1.8V



Pin	Signal	Description	Alternate functions	IO Voltage
9	MICIN1P	Microphone positive input1		1.8V
10	MICIN2N	Microphone negative input2		1.8V
11	MICIN2P	Microphone positive input2		1.8V
12	AGND	Audio Ground		0V
13	LINEOUTLP	Line left positive output		0.6V
14	LINEOUTLN	Line left negative output		0.6V
15	LINEOUTRN	Line right negative output		0.6V
16	LINEOUTRP	Line right positive output		0.6V
17	HPOUTL	Headphone left channel output		0.6V
18	HPOUTFB	Headphone Feedback		0V
19	HPOUTR	Headphone right channel output		0.6V
20	RTC-BAT	RTC power output		1.8-3.3V
21	LRADC0	Key 6bit ADC input(PU10K)	Boot mode (Note1)	1.8V
22	GPADC17	ADC17 8bit ADC input		1.8V
23	GPADC18	ADC18 8bit ADC input		1.8V
24	PG10_1V8	I2S1_MCLK output	PG10/EINT10	1.8V
25	AP-RESET	Reset key input		1.8V
26	RTC-32KO	RTC clock output(PU10K)		1.8V
27	USB0- VBUSDET_1V8	USB0 VBUS input		1.8V
28	USB0-ID	S-PWM0/DMIC_DATA0/S- SPI0_CS0	PL10/EINT10	3.3V
29	S-TWI2-RTC-SCK	S-PWM8/DMIC-DATA2/S- UART0_TX/S- SPI0_MOSI(PU10K)	PL12/EINT12(Note2)	3.3V
30	S-TWI2-RTC-SDA	S-PWM9/DMIC-DATA3/S- UART0_RX/S- SPI0_MISO(PU10K)	PL13/EINT13(Note2)	3.3V
31	CPUS-TX	S-UART0/1_TX/S-PWM2	PL2/EINT2	3.3V
32	CPUS-RX	S-UART0/1_RX/S-PWM3	PL3/EINT3	3.3V
33	LCD1-BL-PWM	UART5_RTS/SPI1_MOSI/PWM 5/I2S2_DOUT0/DIN1	PI4/EINT4	3.3V
34	LCD0-BL-PWM	UART5_RX/SPI1_CLK/PWM4/I2 S2_LRCK	PI3/EINT3	3.3V
35	LCD1-BL-PWREN	UART5_CTS/SPI1_MISO/PWM 6/I2S2_DOUT1/DIN0	PI5/EINT5	3.3V
36	LCD0-BL-PWREN	UART5_TX/SPI1_CS0/PWM3/I2 S2_BCLK	PI2/EINT2	3.3V
37	TWI5-SDA	DMIC_DATA2/PWM10	PI9/EINT9	3.3V
38	TWI5-SCK	IR-RX/PWM9	PI8/EINT8	3.3V
39	UART3-232-TX	DMIC_DATA0/PWM12	PI11/EINT11	3.3V
40	UART3-232-RX	PWM13	PI12/EINT12	3.3V



Pin	Signal	Description	Alternate functions	IO Voltage
41	OWA-OUT	DMIC_DATA1/I2S2_MCLK/PWM11	PI10/EINT10	3.3V
42	CAN0-CPUS-TX	S-PWM4	PL4/EINT4	3.3V
43	CAN0-CPUS-RX	S-PWM5/DMIC-DATA3	PL5/EINT5	3.3V
44	S-TWI1-AC107-SCK	DMIC-DATA0	PL8/EINT8	3.3V
45	S-TWI1-AC107-SDA	S-PWM1/DMIC-CLK	PL9/EINT9	3.3V
46	AUDIO-MUTE	S-PWM7/DMIC-DATA1	PL7/EINT7	3.3V
47	S-IR-RX	DMIC-DATA1/S-SPI0_CLK	PL11/EINT11	3.3V
48	UART4-232-TX	TWI4_SCK/PWM1/I2S2_DIN3/DOUT3	PI0/EINT0	3.3V
49	UART4-232-RX	TWI4_SDA/PWM2/I2S2_DIN2/DOUT2	PI1/EINT1	3.3V
50	CAN0-TX	UART3_RTS/TWI2_SCK/PWM16	PI15/EINT15	3.3V
51	CAN0-RX	UART3_CTS/TWI2_SDA/PWM17	PI16/EINT16	3.3V
52	CTP1-RST	DMIC_CLK/PWM15	PI14/EINT14	3.3V
53	CTP1-INT	DMIC_DATA3/PWM14/I2S2_MCLK	PI13/EINT13	3.3V
54	GND	Ground		0V
55	LCD1-D20	UART2_TX/UART3_RTS/SPI0_CS0	J20/EINT20	3.3V
56	LCD1-D21	UART2_RX/UART3_CTS/SPI0_CLK	J21/EINT21	3.3V
57	LCD1-D22	UART2_RTS/UART3_RX/SPI0_MOSI	J22/EINT22	3.3V
58	LCD1-D23	UART2_CTS/UART3_TX/SPI0_MISO	J23/EINT23	3.3V
59	UART-0-CPUX-TX	TWI0_SCK/I2S0_DIN2/DOUT2 (Debug Uart)	PB9/EINT9	3.3V
60	UART-0-CPUX-RX	TWI0_SDA/PWM1/I2S0_DIN3/DOUT3 (Debug Uart)	PB10/EINT10	3.3V
61	I2S0-LRCK	PWM10/HDMI_CEC	PB6/EINT6	3.3V
62	I2S0-DOUT	OWA_IN/I2S0_DIN1/PWM11	PB7/EINT7	3.3V
63	I2S0-DIN	OWA_OUT/I2S0_DO1/PWM0	PB8/EINT8	3.3V
64	I2S0-MCLK	TWI1_SCK/PWM8/HDMI_SCL	PB4/EINT4	3.3V
65	I2S0-BCLK	TWI1_SDA/PWM9/HDMI_SDA	PB5/EINT5	3.3V
66	FEL	Boot mode select: Low: download from USB, High: fast boot		3.3V
67	SDC0-DET	I2S3_MCLK	PF6/EINT6	3.3V
68	LCD0-HSYNC	UART2_TX/UART4_RTS/PWM2	PD20/EINT20	3.3V



Pin	Signal	Description	Alternate functions	IO Voltage
69	LCD0-VSYNC	UART2_Rx/UART4_CTS/PWM3	PD21/EINT21	3.3V
70	PCIE21-CLKREQn	IR_RX	PH19/EINT19	3.3V
71	PCIE21-WAKEn		PH12/EINT12	3.3V
72	PCIE21-PERSTn		PH11/EINT11	3.3V
73	GND	Ground		0V
74	LVDS1-D3N	DSI1_D3N/LCD0_DE/UART4_RX/PWM19	PD19/EINT19	0.6V/3.3V
75	LVDS1-D3P	DSI1_D3P/LCD0_CLK/UART4_TX/PWM18	PD18/EINT18	0.6V/3.3V
76	LVDS1-CKN	DSI1_D2N/LCD0_D23/UART3_CTS/PWM17	PD17/EINT17	0.6V/3.3V
77	LVDS1-CKP	DSI1_D2P/LCD0_D22/UART3_RTS/PWM16	PD16/EINT16	0.6V/3.3V
78	LVDS1-D2N	DSI1_CLKN/LCD0_D21/UART3_RX/PWM15	PD15/EINT15	0.6V/3.3V
79	LVDS1-D2P	DSI1_CLKP/LCD0_D20/UART3_TX/PWM14	PD14/EINT14	0.6V/3.3V
80	LVDS1-D1N	DSI1_D1N/LCD0_D19/SPI1_MISO/PWM13/DBI_SDI/TE	PD13/EINT13	0.6V/3.3V
81	LVDS1-D1P	DSI1_D1P/LCD0_D18/SPI1_MOSI/PWM12/DBI_SDO	PD12/EINT12	0.6V/3.3V
82	LVDS1-D0N	DSI1_D0N/LCD0_D15/SPI1_CLK/PWM11/DBI_SCLK	PD11/EINT11	0.6V/3.3V
83	LVDS1-D0P	DSI1_D0P/LCD0_D14/SPI1_CS0/PWM10/DBI_CSX	PD10/EINT10	0.6V/3.3V
84	LVDS0-D3N	DSI0_D3N/LCD0_D13/PWM9	PD9/EINT9	0.6V/3.3V
85	LVDS0-D3P	DSI0_D3P/LCD0_D12/PWM8	PD8/EINT8	0.6V/3.3V
86	LVDS0-CKN	DSI0_D2N/LCD0_D11/PWM7	PD7/EINT7	0.6V/3.3V
87	LVDS0-CKP	DSI0_D2P/LCD0_D10/PWM6	PD6/EINT6	0.6V/3.3V
88	LVDS0-D2N	DSI0_CKN/LCD0_D7/PWM5	PD5/EINT5	0.6V/3.3V
89	LVDS0-D2P	DSI0_CKP/LCD0_D6/PWM4	PD4/EINT4	0.6V/3.3V
90	LVDS0-D1N	DSI0_D1N/LCD0_D5/PWM3	PD3/EINT3	0.6V/3.3V
91	LVDS0-D1P	DSI0_D1P/LCD0_D4/PWM2	PD2/EINT2	0.6V/3.3V
92	LVDS0-D0N	DSI0_D0N/LCD0_D3/PWM1	PD1/EINT1	0.6V/3.3V
93	LVDS0-D0P	DSI0_D0P/LCD0_D2/PWM0	PD0/EINT0	0.6V/3.3V
94	GND	Ground		0V
95	USB1-DM			3.3V
96	USB1-DP			3.3V
97	USB2-DM	(Note5)		3.3V
98	USB2-DP	(Note5)		3.3V
99	USB0-DM			3.3V
100	USB0-DP			3.3V



Pin	Signal	Description	Alternate functions	IO Voltage
101	HHPD	HDMI_HPDP		5V
102	HCEC	HDMI_GEC		3.3V
103	HSDA	HDMI_SDA		5V
104	HSCL	HDMI_SCL		5V
105	TWI4-AUDIO-SDA_1V8	UART5_RX/UART6_CTS/SPI2_MISO	PE14/EINT14	1.8V
106	TWI4-AUDIO-SCK_1V8	UART5_TX/UART6_RTS/SPI2_MOSI	PE13/EINT13	1.8V
107	UART6-TX_1V8	UART5_RTS/SPI2_CS0	PE11/EINT11	1.8V
108	UART6-RX_1V8	UART5_CTS/SPI2_CLK	PE12/EINT12	1.8V
109	MCSIC-SCK_1V8	TWI3_SCK/UART4_RTS	PE3/EINT3	1.8V
110	MCSIC-SDA_1V8	TWI3_SDA/UART4_CTS	PE4/EINT4	1.8V
111	MCSIA-SCK_1V8	TWI2_SCK/UART4_TX	PE1/EINT1	1.8V
112	MCSIA-SDA_1V8	TWI2_SDA/UART4_RX	PE2/EINT2	1.8V
113	GND	Ground		0V
114	HTXCN	HDMI_TXCLKN		0.6V
115	HTXCP	HDMI_TXCLKP		0.6V
116	HTX0N	HDMI_TX0N		0.6V
117	HTX0P	HDMI_TX0P		0.6V
118	HTX1N	HDMI_TX1N		0.6V
119	HTX1P	HDMI_TX1P		0.6V
120	HTX2N	HDMI_TX2N		0.6V
121	HTX2P	HDMI_TX2P		0.6V
122	U3-PCIE21-RXN	USB3_RXN/PCIE_RX0N		0.6V
123	U3-PCIE21-RXP	USB3_RXP/PCIE_RX0P		0.6V
124	U3-PCIE21-TXN	USB3_TXN/PCIE_TX0N		0.6V
125	U3-PCIE21-TXP	USB3_TXP/PCIE_TX0P		0.6V
126	PCIE21-REFCLKN			0.6V
127	PCIE21-REFCLKP			0.6V
128	SDC0-D1	I2S3_DIN0/DOUT1	PF0-EINT0	3.3V
129	SDC0-D0	I2S3_DOUT0/DIN1	PF1-EINT1	3.3V
130	SDC0-CLK	UART0_TX/I2S3_DIN2/DOUT2	PF2-EINT2	3.3V
131	SDC0-CMD	I2S3_LRCK	PF3-EINT3	3.3V
132	SDC0-D3	UART0_RX/I2S3_DIN3/DOUT3	PF4-EINT4	3.3V
133	SDC0-D2	I2S3_BCK	PF5-EINT5	3.3V
134	GND	Ground		0V
135	MCSIA-D0N	MIPI_CSIA_D0N	PK0/EINT0	0.6V/3.3V
136	MCSIA-D0P	MIPI_CSIA_D0P	PK1/EINT1	0.6V/3.3V
137	MCSIA-D1N	MIPI_CSIA_D1N	PK2/EINT2	0.6V/3.3V
138	MCSIA-D1P	MIPI_CSIA_D1P	PK3/EINT3	0.6V/3.3V
139	MCSIA-CKN	MIPI_CSIA_CKN/TWI2_SCK	PK4/EINT4	0.6V/3.3V
140	MCSIA-CKP	MIPI_CSIA_CKP/TWI2_SDA	PK5/EINT5	0.6V/3.3V



Pin	Signal	Description	Alternate functions	IO Voltage
141	MCSIB-D0N(Notes3)	MIPI_CSIA_D2N	PK6/EINT6	0.6V/3.3V
142	MCSIB-D0P(Notes3)	MIPI_CSIA_D2P	PK7/EINT7	0.6V/3.3V
143	MCSIB-D1N(Notes3)	MIPI_CSIA_D3N	PK8/EINT8	0.6V/3.3V
144	MCSIB-D1P(Notes3)	MIPI_CSIA_D3P	PK9/EINT9	0.6V/3.3V
145	MCSIC-D0N	UART7_TX/TWI4_SCK/NCSI_P CLK	PK12/EINT12	0.6V/3.3V
146	MCSIC-D0P	UART7_RX/TWI4_SDA/NCSI_M CLK	PK13/EINT13	0.6V/3.3V
147	MCSIC-D1N	UART7_RTS/UART5_RTS/NCSI _HSYNC	PK14/EINT14	0.6V/3.3V
148	MCSIC-D1P	UART7_CTS/UART5_CTS/NCS I_VSYNC	PK15/EINT15	0.6V/3.3V
149	MCSIC-CKN	TWI5_SCK/UART5_TX/NCSI_D 0	PK16/EINT16	0.6V/3.3V
150	MCSIC-CKP	TWI5_SDA/UART5_RX/NCSI_D 1	PK17/EINT17	0.6V/3.3V
151	MCSID-D0N	MCSIC- D2N/NCSI0_MCLK/UART6_TX/ NCSI_D2	PK18/EINT18	0.6V/3.3V
152	MCSID-D0P	MCSIC- D2P/TWI2_SCK/UART6_RX/NC SI_D3	PK19/EINT19	0.6V/3.3V
153	MCSID-D1N	MCSIC- D3N/TWI2_SDA/UART6_RTS/N CSI_D4	PK20/EINT20	0.6V/3.3V
154	MCSID-D1P	MCSIC- D3P/NCSI1_MCLK/UART6_CT S/NCSI_D5	PK21/EINT21	0.6V/3.3V
155	MCSID-CKN	TWI3_SCK/PWM6/NCSI_D6	PK22/EINT22	0.6V/3.3V
156	MCSID-CKP	TWI3_SDA/PWM7/NCSI_D7	PK23/EINT23	0.6V/3.3V
157	MCSIC-MCLK_1V8	PWM2	PE15/EINT15	1.8V
158	LED1/CFG-LDO0	Ethernet LED+		3.3V
159	LCD1-CLK	TWI4_SCK/UART4_TX/SPI0_C S1	PJ24/EINT24	3.3V
160	LCD1-DE	TWI4_SDA/UART4_RX/SPI0_W P	PJ25/EINT25	3.3V
161	LCD1-HSYNC	TWI5_SCK/UART4_RTS/SPI0_ HOLD	PJ26/EINT26	3.3V
162	LCD1-VSYNC	TWI5_SDA/UART4_CTS	PJ27/EINT27	3.3V
163	LED0/CFG-EXT	Ethernet LED+		3.3V
164	MDIO+	Ethernet MDIO+		0.6V
165	MDIO-	Ethernet MDIO-		0.6V



Pin	Signal	Description	Alternate functions	IO Voltage
166	MDI1+	Ethernet MDI1+		0.6V
167	MDI1-	Ethernet MDI1-		0.6V
168	MDI2+	Ethernet MDI2+		0.6V
169	MDI2-	Ethernet MDI2-		0.6V
170	MDI3+	Ethernet MDI3+		0.6V
171	MDI3-	Ethernet MDI3-		0.6V
172	GND	Ground		0V
173	LVDS2-D0N	LCD1_D1/RMII1_RXD0	PJ1/EINT1	0.6V/3.3V
174	LVDS2-D0P	LCD1_D0/RMII1_RXD1	PJ0/EINT0	0.6V/3.3V
175	LVDS2-D1N	LCD1_D3/RMII1_RXER	PJ3/EINT3	0.6V/3.3V
176	LVDS2-D1P	LCD1_D2/RMII1_CRS_DV	PJ2/EINT2	0.6V/3.3V
177	LVDS2-D2N	LCD1_D5/RMII1_TXD0	PJ5/EINT5	0.6V/3.3V
178	LVDS2-D2P	LCD1_D4/RMII1_TXD1	PJ4/EINT4	0.6V/3.3V
179	LVDS2-CKN	LCD1_D7/RMII1_TXEN	PJ7/EINT7	0.6V/3.3V
180	LVDS2-CKP	LCD1_D6/RMII1_TXCK	PJ6/EINT6	0.6V/3.3V
181	LVDS2-D3N	LCD1_D9/RMII1_MDIO	PJ9/EINT9	0.6V/3.3V
182	LVDS2-D3P	LCD1_D8/RMII1_MDC	PJ8/EINT8	0.6V/3.3V
183	LVDS3-D0N	LCD1_D11(Notes4)	PJ11/EINT11	0.6V/3.3V
184	LVDS3-D0P	LCD1_D10/EPHY_25M	PJ10/EINT10	0.6V/3.3V
185	LVDS3-D1N	LCD1_D13(Notes4)	PJ13/EINT13	0.6V/3.3V
186	LVDS3-D1P	LCD1_D12(Notes4)	PJ12/EINT12	0.6V/3.3V
187	LVDS3-D2N	LCD1_D15(Notes4)	PJ15/EINT15	0.6V/3.3V
188	LVDS3-D2P	LCD1_D14(Notes4)	PJ14/EINT14	0.6V/3.3V
189	LVDS3-CKN	LCD1_D17	PJ17/EINT17	0.6V/3.3V
190	LVDS3-CKP	LCD1_D16	PJ16/EINT16	0.6V/3.3V
191	LVDS3-D3N	LCD1_D19	PJ19/EINT19	0.6V/3.3V
192	LVDS3-D3P	LCD1_D18	PJ18/EINT18	0.6V/3.3V
193	GND	Ground		0V
194	WL-SDIO-D1_1V8	PCIE0_WAKEN	PG3/EINT3	1.8V
195	WL-SDIO-D0_1V8	PCIE0_PERSTN	PG2/EINT2	1.8V
196	WL-SDIO-CMD_1V8		PG1/EINT1	1.8V
197	WL-SDIO-CLK_1V8		PG0/EINT0	1.8V
198	WL-SDIO-D3_1V8		PG5/EINT5	1.8V
199	WL-SDIO-D2_1V8	PCIE0_CLKREQN	PG4/EINT4	1.8V
200	BT-PCM-DOUT_1V8	I2S1_DOUT0/DIN1	PG13/EINT13	1.8V
201	BT-PCM-SYNC_1V8	I2S1_LRCK	PG12/EINT12	1.8V
202	BT-PCM-DIN_1V8	I2S1_DIN0/DOUT1	PG14/EINT14	1.8V
203	BT-PCM-CLK_1V8	I2S1_BCLK	PG11/EINT11	1.8V
204	BT-UART-RTS_1V8	UART1_RTS	PG8/EINT8	1.8V



Pin	Signal	Description	Alternate functions	IO Voltage
205	BT-UART-RX_1V8	UART1_RX	PG7/EINT7	1.8V
206	BT-UART-TX_1V8	UART1_TX	PG6/EINT6	1.8V
207	BT-UART-CTS_1V8	UART1_CTS	PG9/EINT9	1.8V
208	WL-REG-ON_1V8	S-UART0/1_RX/S-PWM3	PM1/EINT1	1.8V
209	AP-WAKE-BT_1V8		PE9/EINT9	1.8V
210	WL-WAKE-AP_1V8	S-UART0/1_TX/S-PWM2	PM0/EINT0	1.8V
211	BT-RESETN_1V8	S-PWM6	PM2/EINT2	1.8V
212	BT-WAKE-AP_1V8	S-PWM8	PM4/EINT4	1.8V

Note

1. Setting LRADC0=L will make boot error when power on.
2. Use for I2C function default, if no need Ext-RTC can change to other GPIO function.
3. Only can used for MIPI CSI A.
4. Difference router for LVDS default, so Not recommended use for RGMII.
5. USB2 can not used with PCIE simultaneously.

1.7 Development Kit (IdeaT527)

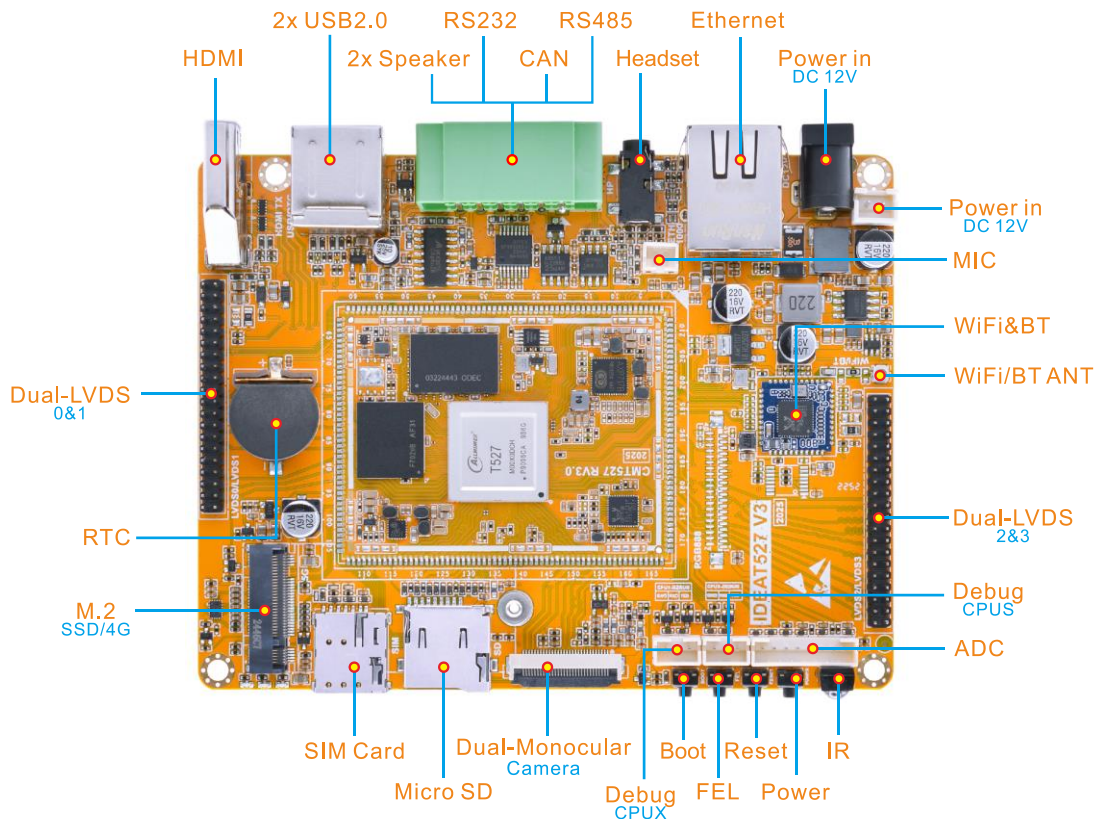

2.2 Display combination

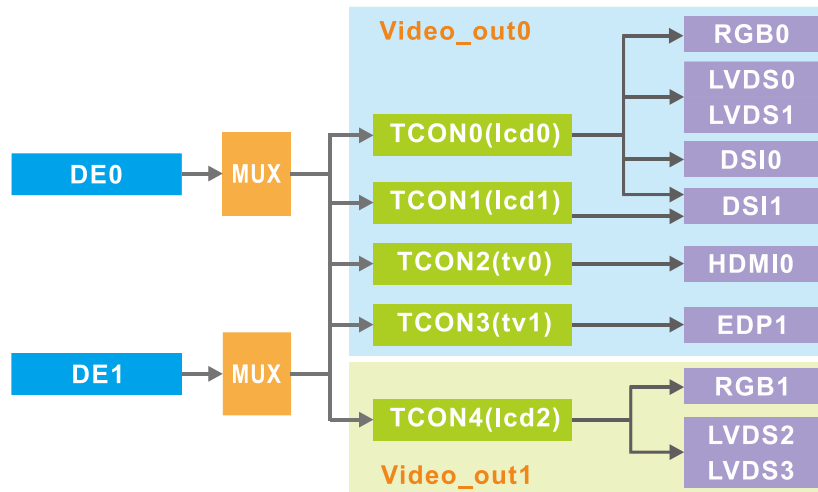

3 Product Electrical Characteristics

3.1 Dissipation and Temperature

Symbol	Parameter	Min	Typ	Max	Unit
DCIN	System Voltage	3.9	5	5.5	V
Idcin	DCIN input Current		1500		mA
DCDC4_3V3	Peripheral Voltage	3.0	3.3	3.35	V
Iout	DCDC4 output Current			600	mA
VCC_RTC	RTC Voltage	1.8	3	3.4	V
Irtc	RTC input Current		5	8	uA
Ta	Operating Temperature	-40		85	°C
Tstg	Storage Temperature	-40		120	°C

3.2 Certifications



Certificate of Conformity

NO.: ENS2411260020E0021C

The following product has been tested by us with the listed standards and found in conformity with the council EMC directive 2014/30/EU. This is to certify that the specimen is in conformity with the assessment requirement mentioned follow. This certificate does not imply assessment to the production of the product.

Applicant : BOARDCON EMBEDDED DESIGN LIMITED

Address : 2508-2509 Haofang Tianji Plaza, 11008 Beihuan Avenue,
Nanshan District, Shenzhen, Guangdong, China. 518051

Manufacturer : BOARDCON EMBEDDED DESIGN LIMITED

Address : 2508-2509 Haofang Tianji Plaza, 11008 Beihuan Avenue,
Nanshan District, Shenzhen, Guangdong, China. 518051

Trade Mark : 

EUT : CMT527 system on module

M/N : CMT527

Test Standards : EN 55032: 2015+A1:2020
EN IEC 61000-3-2: 2019+A1:2021
EN 61000-3-3: 2013+A2:2021
EN 55035: 2017+A11:2020

Version : Ver.1.0



(Manager)
December 19, 2024

The certificate is based on a single evaluation of one sample of above-mentioned products, it does not imply an assessment of the whole production and does not permit the use of the test lab logo.

EMTEK (Shenzhen) Co., Ltd.
Add: Building 69, Majialong Industry Zone, Nanshan District, Shenzhen, Guangdong, China [Http://www.emtek.com.cn](http://www.emtek.com.cn) E-mail: cs.rep@emtek.com.cn

